

INSTALLATION INSTRUCTIONS FOR TYPE 1 DUAL HPMX ULTRA LINKAGE

READ THOROUGHLY ALL STEPS OF THESE INSTRUCTIONS BEFORE BEGINNING THIS INSTALLATION.

The following instructions are based on an engine in stock condition. If you have made modifications to your engine, some of the following steps may not apply to your application.

BENCH ASSEMBLY

1. Install the throttle levers and spacers (See Figures 1 & 2). On left carburetor it will be necessary to install the throttle stop tab prior to installing the throttle lever. It will also be necessary to move the idle speed screw to the other side of carburetor. (The side with new levers installed). Install long spacer on left carburetor and shorter spacer on right carburetor. Re-install throttle shaft nuts on each carburetor. (**DO NOT OVER TIGHTEN NUTS, 4-5 FT/LBS MAXIMUM**). Bend lock tab against nut to hold nut tight.
2. Slide the center pull-lever and the left and right extension arms onto the hex bar so there is approximately 60° between the centerline of the arms compared to the center pull lever (See Figure 3). Install retention hardware onto the parts, but **DO NOT** fully tighten at this time. Install the jam nuts onto the ball-ends and thread the ball-ends into each end of the hex bar.

FINAL INSTALLATION

1. Install the linkage mount air cleaner base (See Figure 4) (Leave off element and A/C top) on the left-side (Driver's Side) carburetor, using the lockwashers and nuts provided. (On some models stud removal may be necessary, go ahead and remove studs. Use short and long 6mm bolts and lockwashers that are supplied). **NOTE: DO NOT INSTALL THE RIGHT SIDE COMPONENTS AT THIS TIME. DUE TO THE LENGTH REQUIRED FOR THE HEX BAR TO SEAT PROPERLY IN THE BRACKET, THE RIGHT AND LEFT SIDE ASSEMBLY OF PARTS CANNOT BE DONE SIMULTANEOUSLY.**
2. Install the plastic sleeve into the left hex bar linkage bracket then install the self-centering spring inside the left bracket bushing.
3. Insert the left hand ball-end of the hex bar assembly into the left bracket bushing and centering spring. Temporarily support to perform next step.
4. Install the linkage mount and air cleaner base (Leave off element and A/C top) on the right-side carburetor. **DO NOT BOLT DOWN COMPONENTS.** Install the bushing and the centering spring. Unbrace the hex bar and insert the ball-end into the right bracket bushing. Once the hex bar has seated in the bushing, secure the assembly down using the lockwashers and nuts (or bolts) provided. **NOTE: THE HEX BAR AND BALL-ENDS HAVE BEEN DESIGNED WITH SUFFICIENT THREAD LENGTH TO ACCOMMODATE CUTTING THE BAR IF NECESSARY OR EXTENDING THE BAR ENDS OUT TO GAIN PROPER INSTALLATION. BAR CAN BE CUT APPROXIMATELY 1" ON EITHER END AND STILL HAVE SUFFICIENT THREAD FOR BALL-END INSTALLATION.**
5. Adjust the hex bar ball-ends to achieve a 1/32" clearance between the bushing flange and ball flange. Once the ball-ends are adjusted correctly, lock the jam nuts in place (See Figure 1).
6. Install the carburetor linkage rods to each of the extension arms on the hex bar and to the spacers on carburetor throttle levers (See Figures 1 & 2). At this time tighten rod ends fully at carburetor spacers, set linkage rod length to center of adjustment with jam nuts loose, and fully tighten rod ends at hex bar extension arms. Location of hex bar arms should be almost to end of bar so down rods are "centered" vertically. Extension arms (on hex bar) should be fully tightened at this time. **CAUTION: BE SURE CENTER PULL LEVER IS POSITIONED FOR CORRECT THROTTLE CABLE HOOK-UP, AT IDLE AND FULL THROTTLE POSITIONS. CHECK THROTTLE OPERATION FOR FREE MOVEMENT. IF THERE IS ANY INDICATIONS OF STICKING OR BINDING, CORRECT AS NECESSARY BEFORE PROCEEDING.**
7. Install the throttle cable trunion and shortner. Align the center pull lever on the hex bar with the throttle cable and tube. Secure it in place by tightening the set screw.
8. Position the stock throttle cable next to the shortner and measure the excess cable to be cut.
9. Once you have correctly measured the amount of cable to be removed, cut the cable. Install the new cable end into the shortner. Lock the cable in place by tightening down the set screw. **NOTE: WHEN SETTING THE CABLE ADJUSTMENT AT CENTER PULL LEVER, BE SURE TO SET AT "FULL THROTTLE POSITION". THIS MEANS THE ACCELERATOR PEDAL SHOULD BE AT "FULL STOP" AND THEN CABLE IS SET AT CARBURETOR "FULL THROTTLE STOP". THIS WILL KEEP YOU FROM OVER-EXTENDING YOUR CARBURETOR LINKAGE AND THROTTLE SHAFTS.**
10. Complete the installation of the air filter assemblies.
11. **CHECK FOR ADEQUATE HOOD CLEARANCE BEFORE CLOSING THE HOOD.**

Figure 1
(Left View)

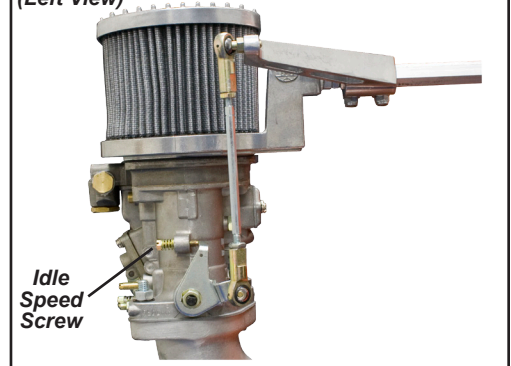

Figure 2
(Right View)

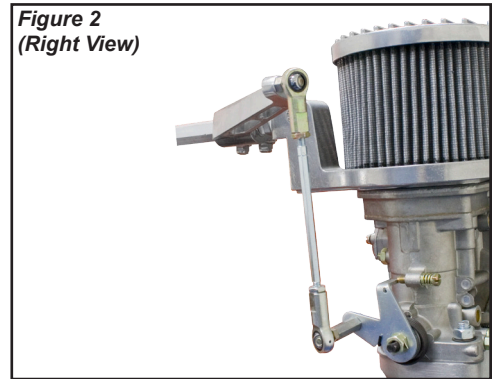

Figure 3

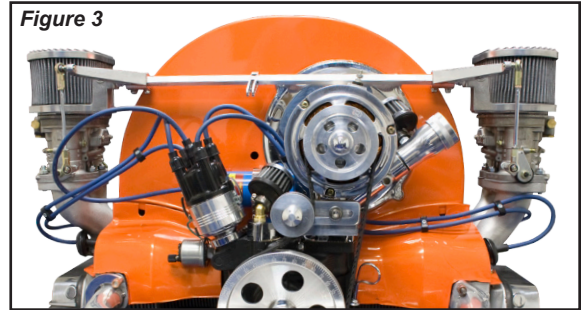

Figure 4

