





INSTALLATION MANUAL

HEI DISTRIBUTOR

00-9442-7

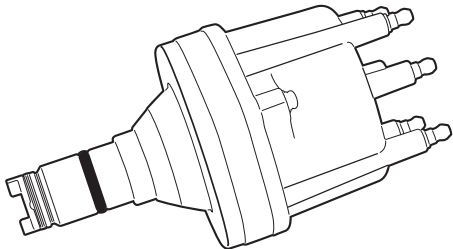
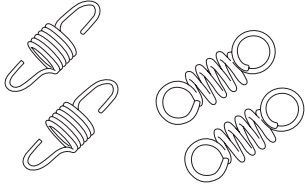
PACKAGE CONTENTS:

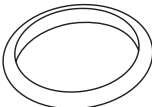
ITEM	QTY.	DESCRIPTION	
A	1	HEI Distributor	
B	6	Centrifugal Advance Springs: •Red = Light (20 AWG/6 coils) •Silver = Med (20 AWG/4 coils) •Black = Heavy (18AWG/4 coils) <i>*Silver set pre-installed.</i>	
C	4	Advance Stop Bushings Silver = Light (7mm OD) 14 deg limit Bronze = Med 1 (8mm OD) 12 deg limit Black = Med 2 (8.7mm OD) 10 deg limit Gold = Heavy (9.5mm OD) 8 deg limit <i>*Bronze set pre-installed.</i>	
D	1	Spare O-ring	

TOOLS REQUIRED:

- Phillips screw driver
- Needle nose pliers
- Hex Key

BEFORE YOU BEGIN:

Please read this installation manual completely before you begin the installation.

1 Remove distributor cap before installing.

2 Place the distributor through the distributor clamp. Clamp should be secured to the engine case.

3 On initial setup, the tip of the distributor rotor (**Figure 2**) should be aligned with the # 1 marker on the distributor cap (**Figure 1**). Depending on the initial advance and distributor drive gear this alignment may change.

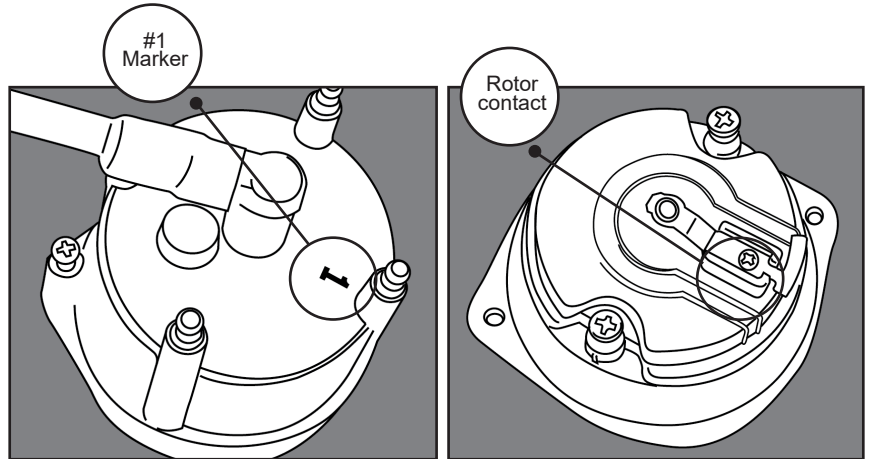

Figure 1: #1 marker

Figure 2: Rotor tip

4 Confirm that the distributor is fully seated before tightening the distributor clamp with a hex key.

5 **Connect Wires:** The ignition module connects to the ignition coil (**Figure 3**). The Red wire goes to the 12V (+) terminal on the coil. The Black wire goes to the negative (-) terminal of the coil.

****Use caution as incorrect wiring may lead to damage to the distributor.****

Please confirm correct wiring before continuing.

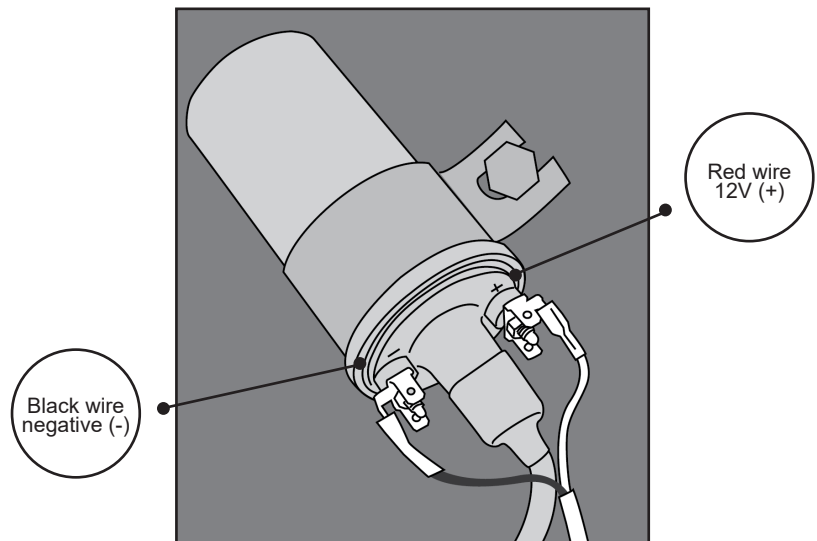

Figure 3: Connect to ignition coil

6 Connect spark plug wires before starting the engine. Set the timing to the desired degrees of advance and installation is complete.

Changing Advance Springs: Select and install the advance springs to achieve your desired performance. The lighter spring will provide quicker advance timing.

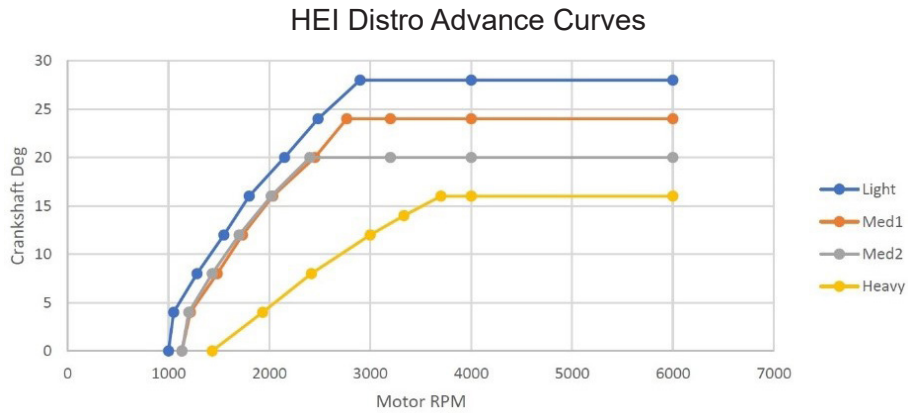

Figure 4: Light = light spring/light bushing, Med1 = med spring/med1 bushing, Med2 = med spring/med2 bushing, Heavy = heavy spring/heavy bushing.

7

To change the advance spring remove the red rotor cap to expose the fly weights and springs. Silver springs are installed at the factory.

8

Use needle nose pliers to pull the advance spring off the post (Figure 5). Once one end of the spring is off the other should come off easily. Replace them with your spring of choice and re-install the distributor.

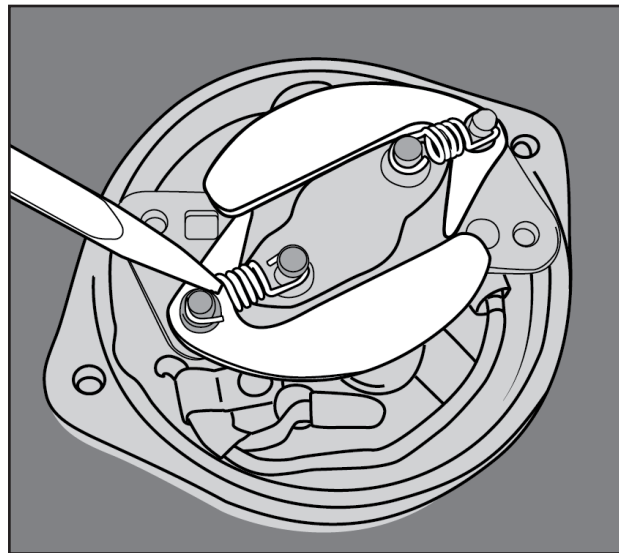
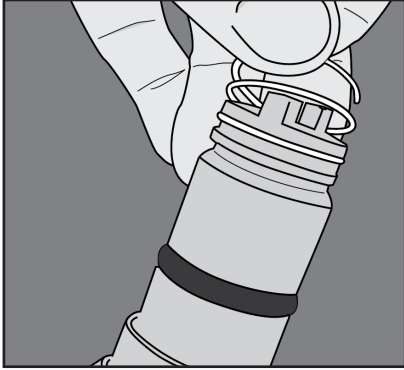
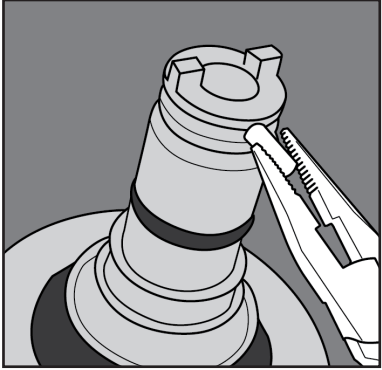
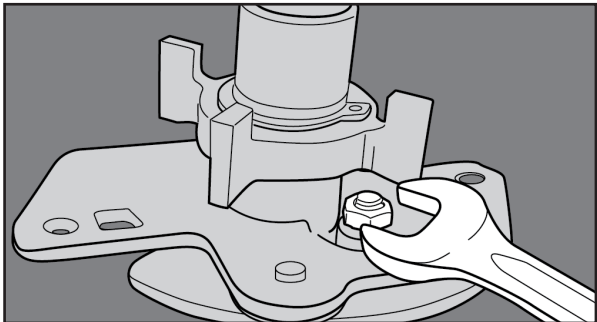
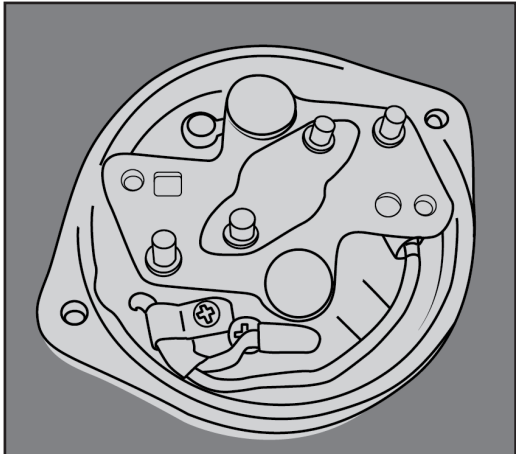

Figure 5: Remove advance springs

Change Advance Stop Bushings: Select and install the stop bushing to achieve the maximum advance desired. Bronze bushings are installed at the factory (12 degree limit).

Example:
 Initial Advance = 10 deg
 Med 1 (mechanical advance) = 12 deg
 Total advance = 28-32 deg

<p>9</p>	<p>To change the advance stop bushing remove retaining clip (Figure 6) and lock pin (Figure 7) from the bottom of the distributor shaft.</p>	<div style="display: flex; justify-content: space-around;">   </div> <p style="text-align: center;"><i>Figure 6: Remove clip</i> <i>Figure 7: Remove pin</i></p>
<p>10</p>	<p>Once this is done the shaft can be pulled out of the bearing housing to access the stop bushing post on the underside of the advance assembly (Figure 8). Remove the lock nut and washer to remove the stop bushing and replace with the bushing of your choice and re-install the distributor.</p>	 <p style="text-align: center;"><i>Figure 8: Remove stop bushing</i></p>
<p>Advance lock out If you desire to lock out the advance and hold a specific timing this can be done with the following steps.</p>		
<p>11</p>	<p>Follow the same procedure as Step 7 & 8 to remove the advance springs.</p>	
<p>12</p>	<p>Once the advance springs are off the fly weights can also be removed (Figure 9) as they will not be needed in the locked position.</p>	 <p style="text-align: center;"><i>Figure 9: Fly-weights removed</i></p>
<p>13</p>	<p>Follow the same procedure as Step 9 & 10 to remove the stop bushing.</p>	

14

Once the stop bushing is removed you can now pull out the distributor drive shaft and clear the stop post from the stop bushing cutout.

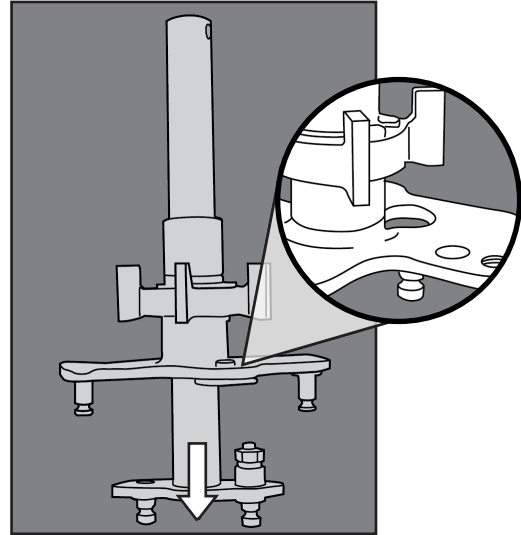

Figure 10: Clear stop bushing from cutout

15

Rotate the distributor drive shaft 180 deg. and insert the stop post into the lock hole opposite the stop bushing cutout (**Figure 11**). Once the drive shaft has been rotated you can screw the lock nut and washer back on the stop post (**Figure 12**) and the lock out is complete.

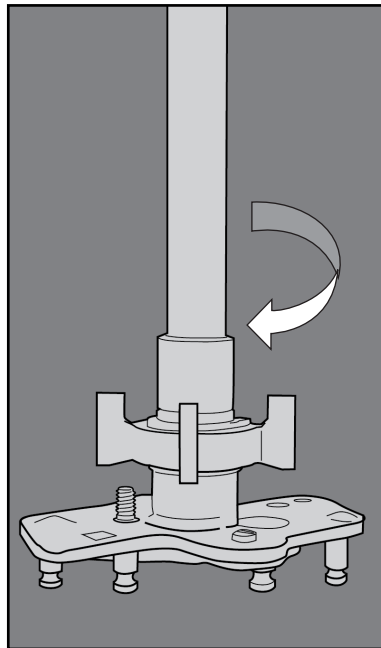

Figure 11: Rotate shaft 180°

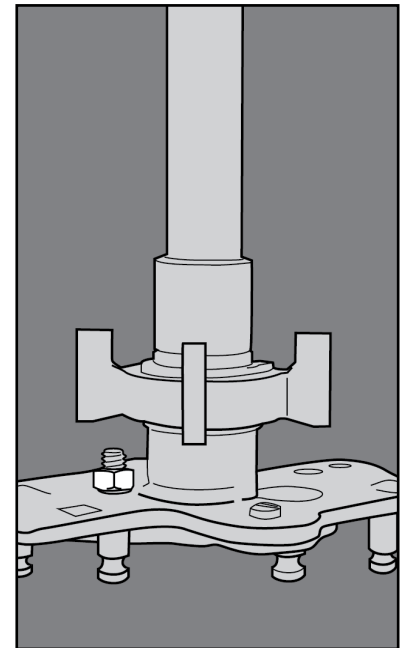

Figure 12: Replace lock nut and washer to complete lock out